

DoD Biometrics Identity Management (BIdM)

Shawn Elliott
Futures Branch, Biometric Task Force
shawn.elliott@hqda.army.mil
28 Feb 2008

Purpose & Content

Purpose: Share Biometric Task Force, Biometric Identity Management (BIdM) concepts to industry & receive feedback

- BIdM Goals and Objectives
- Capabilities
- Current Situation
- Emerging Concepts

**Create BIdM partnerships to achieve
DoD's Identity Management Vision and
Mission**

Biometric Identity Management Strategy

- **Goal:**
 - Define and implement DoD-wide policy, process, and technology in support of biometrics as a key-enabler for identity management.
- **Objectives:**
 - Establish joint collaboration and shared responsibility for the consolidated BIdM capability – integrating role
 - Demonstrate Biometric IdM processes and technologies in an operationally relevant environment
 - Transition proven capability into an operational biometric enterprise

Biometrics IdM Capabilities

DENY ANONYMITY

to persons who seek to harm DoD people or assets

Support BUSINESS EFFICIENCY/EFFECTIVENESS

for operations that benefit from strong identification & verification

- **Identify** - “who” someone is and is not
- **Establish** - “who” someone is, so it can not change
- **Verify** - individuals are “who” they say they are
- **Determine and Notify** - when the disposition of “who” someone is changes

Current DoD Identity Protection & Management (IP&M)

- **Personal Identity Protection**
 - PSA: USD(P&R) (DHRA)
 - DMDC-Access Card Office
 - DoDD 1000.25, DoDD 8190.3
- **Public Key Infrastructure**
 - PSA: ASD (NII)
 - PKI PMO (NSA / DISA) / JTF-GNO
 - DoDD 8500.1 and DoDI 8500.2; DoDD 8520.2
- **Biometrics**
 - PSA: DDR&E
 - Biometrics Task Force
 - Draft Directive DoDD 8521.aa.EE
- **Physical & Personnel Security**
 - PSA: USD(I)
 - Services and Agencies
 - DoDD 5200.08-R, DoDI 5200.08

- **Technology Centric**
- **Operationally Supportive**
- **Opportunity for:**
 - Synergy
 - Overarching IdM Architecture

Current BldM Situation

- **Need** for Common, Interoperable and Integrated Policies, Processes, and Technologies to authoritatively
 - identify and establish human identities represented to the DoD
 - verify human identities represented to the DoD
- **HSPD-12** biometric requirements **evolving**
- **No central, authoritative storage** of 10-prints or other modalities
 - Only MEPCOM interfaces with DMDC for 10-print information
 - No visibility into enrollment/collection channels for biometric 10-prints
 - Duplication of effort for biometric collection
- **Emerging capabilities** to leverage other biometric sources
 - ABIS
 - Law Enforcement
 - US VISIT
- **Emerging standards** and **interoperability**
 - **DISR Baseline**

Notional BldM Detailed Interaction

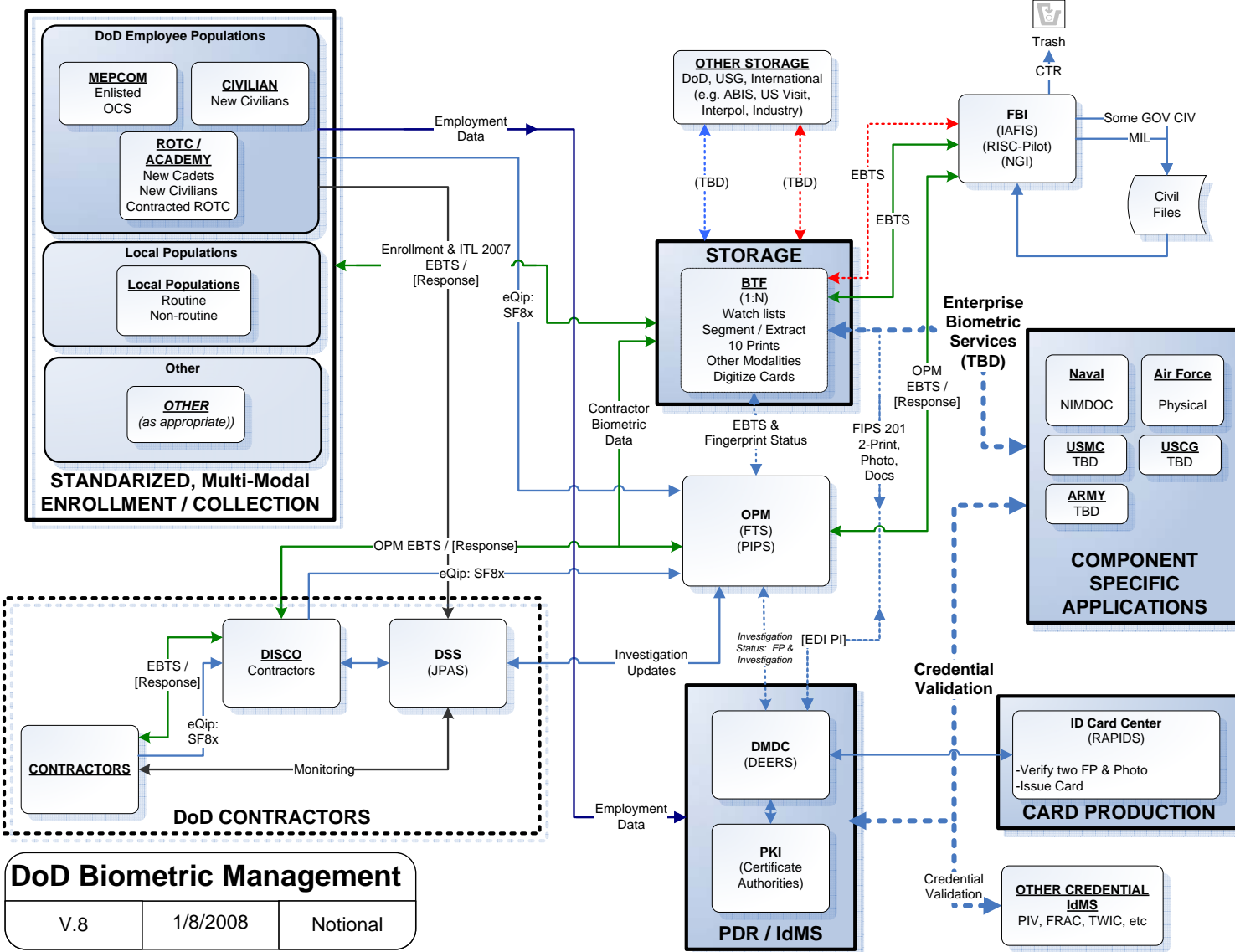

- Authoritative Central storage
- Submissions to DMDC through BTF Hosting
- Visibility into all collection channels
- Access to OPM fingerprint check data
- Strong binding between Identity, 10-print and credential
- Biometric Services for Component specific applications

DoD Biometric Management		
V.8	1/8/2008	Notional

Notional BldM Interaction

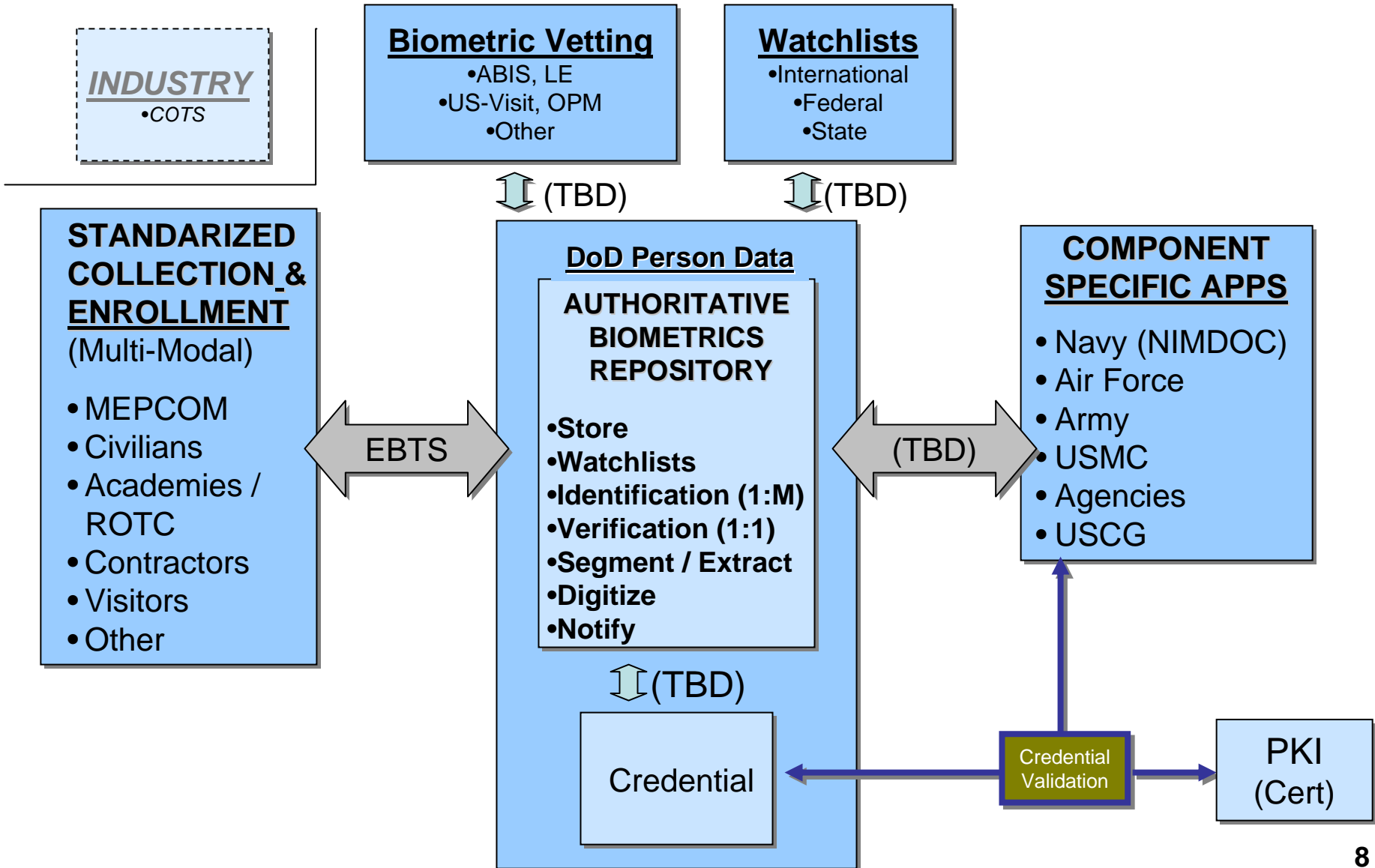

What We Get

- Authoritative Source for Biometrics
- Identity Vetting via Biometrics
 - Initial Vetting
 - “bad guy” searches to ensure that we know who someone is not
 - “good guy” searches to ensure we know who someone is
 - Recurring biometric vetting
- Subsequent Notification
 - Inform participating applications (relying parties), credentialing providers (issuers) and/or law enforcement when identity [biometric] disposition changes
- Alternate modalities supporting biometric identification and verification

Initial BldM Use Cases

- Manage Standardized Enrollment, Collection & Storage of biometrics
- Support Identity Vetting for credentialing
 - PIV Credentials
 - Alternate PIV Credentials
 - Visitors
- Support Background Investigations (Personnel Security Investigations)
- Recurring Biometric Vetting & Subsequent Notification
- Provide PIV Biometric Templates & Photo
- Support Physical Access
 - Attended and unattended
 - Visitor Vetting
- Support Logical Access
 - BIOMETRIC-Enabling
 - Complementary to current methods

DoD Partners

Organization
Defense Manpower Data Center
Air Force Communications Agency (AFCA)
Army G-2
Army G-6, IA Directorate, CAC/PKI Division
DON Identity Management (NIMDOC)
NORTHCOM, J34
USD(AT&L), Defense Biometrics
USD(I), DUSD (CI&S)
ASD(NII), DASD (IIA)
USD(P&R), Defense Human Resources Activity (DHRA)
Personnel Security Research Center (PERSREC)
<i>USD(P&R), Civilian Personnel Policy (CPP)</i>
<i>Defense Security Services (DSS)</i>

BldM Target Timeline

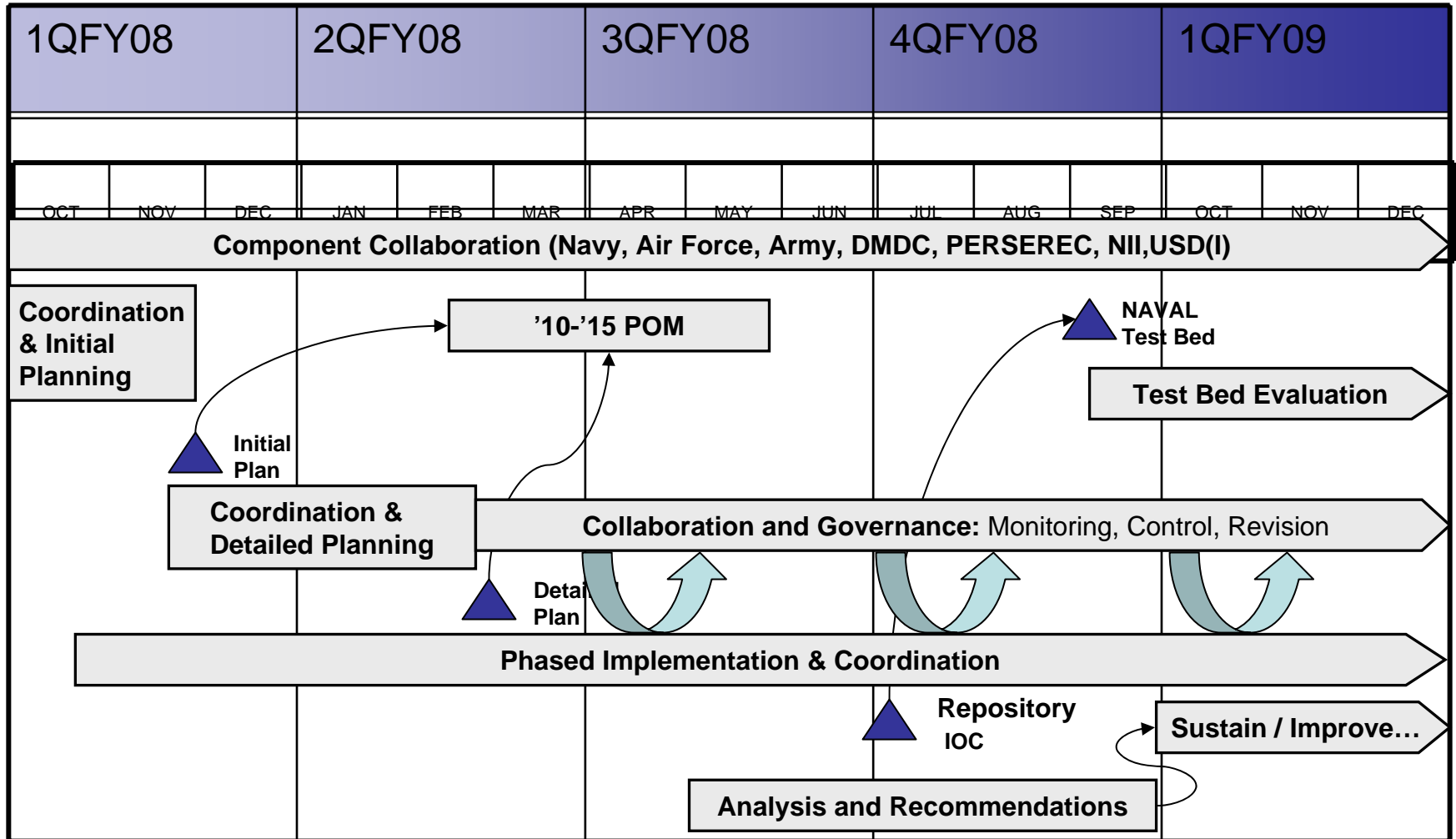

Way Ahead

- Demonstrate BIdM progress within FY08
- Support DoD Component IdM Initiatives
 - HSPD-12 & FIPS 201
 - HSPD-6, 11, 20
 - Access Control
 - Suitability and Clearance Reform
- Continue Collaboration and Governance coordination
- Provide Biometric Services in support of DoD IP&M missions

**Create Biometric IdM partnerships to achieve
DoD's Identity Management Vision and
Mission**



Backup

Evolving Definitions

- Identity Management
 - 1. The Personnel, Policy, Processes, and Technology used to authoritatively establish and manage human identities represented to the DoD. [Futures Division BTF]
 - 2. A business function that authenticates an individual to validate identity, DOD affiliation, and authorization of the credential holder. The centralized data repository delivers credentialing information and status for business functions within DOD for use as proof of identity and DOD affiliation is delivered by Identity Management.[Biometrics CAPSTONE CONOPS]
 - 3. The combination of systems, rules, and procedures that defines an agreement between an individual and organization (s) regarding ownership, utilization, and safeguard of personal identity information and all the collateral information, explicit and inferable, associated with that identity.[DoDD 8521]
- Biometric Identity Management
 - The common, interoperable and integrated Policy, Processes, and Technologies used to authoritatively establish, identify and verify human identities represented to the DoD. [Futures Division BTF]
- Biometrics Enterprise
 - All systems, interfaces and personnel that are utilized to identify and verify identities of people represented to DoD through the use of biometric modalities.[Futures Division BTF]

Evolving Foundations

