

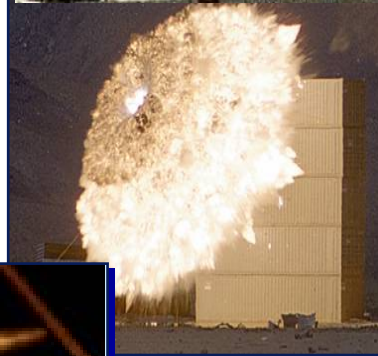

Inensitive Munitions/ Energetic Materials Symposium

Navy Energetics Enterprise

Roger L. Swanson, NOSSA
&
Vicki L. Brady, NAWC/WD



**NOSSA - Leader for Ordnance Safety...
Today and Tomorrow**



Outline

- **Why Navy Energetics?**
- **Navy Energetics Enterprise (NEE)**
- **IM Collaboration Successes**
- **Future Needs**
- **Summary**



What is “Energetics?”

- **Defined as, “...explosives, propellants, pyrotechnics, reactive materials, related chemicals and fuels, and their application in propulsion systems and ordnance...” ***
- **Includes bombs, warheads, mines, fuzes, countermeasures, flares, obscurants, safe-arm devices, arming-firing devices, unguided rockets, missile rocket motors, ramjets, gas generators, gun projectiles and propelling charges, and cartridge and propellant actuated devices.**

* From the signed Navy Energetics Leadership Board (NELB) and Energetics IPT (EIPT) charters

Why Navy Energetics?

- **DOD is nation's undisputed leader in energetics ...especially true for the Navy:**
Navy mission is diverse (Sea Power 21)...covers all environments ... diverse missions require unique energetic solutions:
 - **Sea Strike:**
 - Air launched ordnance...aircraft carrier environment
 - Surface fire support...gun-launched, missiles
 - Time critical strike
 - **Sea Shield:**
 - Operations in a littoral environment...underwater, MCM
 - Ballistic missile defense
 - Anti-shipping missiles
 - **Sea Basing:**
 - Insensitive munitions is an imperative...most demanding environment of all the Services
 - HERO & ESD restrictions
- **All Services have benefited from the Navy's robust Energetics capability**

Energetics is a core military competency...

- **Energetic materials/systems, safe weapons & ordnance, are critical to countless warfighting capabilities**
- **The energetics industry is focused on the near-term:**
 - Development & delivery of quality products and services
 - Little or no sustained investment in Energetics (no commercial market)
- **The laboratories are focused on the near *and* long-term:**
 - Respond to immediate Warfighter needs
 - R&D base as the foundation for future weapons systems
- **New 21st century requirements are constantly changing... rapid response is the key**

Navy Energetics Enterprise

- **A coalition of NAVSEA and NAVAIR components**
 - NAVSEA Ordnance Product Area
 - NAVAIR Weapons and Energetics Department
 - Naval Ordnance Safety & Security Activity (NOSSA)
- **Navy Energetics Leadership Board**
 - Led by SYSCOM Vice Commanders
 - Single Navy voice for Energetics
 - National focus for stewardship of the Navy's organic capability
 - Ensures energetics is strategically focused
 - Provides leadership in envisioning future Navy needs
- **Energetics IPT leads coalition efforts to achieve goals**
 - Collaboration to provide best technical solutions for Warfighter needs
 - Achieve long-term cost avoidance resulting from shared people and facilities

CHINA LAKE, CRANE, DAHLGREN, INDIAN HEAD, NOSSA

Navy Energetics Leadership Board

Membership

- **Navy Energetics Leadership Board:**
 - **Vice Commander, NAVAIR (Chair, even-numbered years)**
 - **Vice Commander, NAVSEA (Chair, odd-numbered years)**
 - **Assistant Commander for Research and Engineering, NAVAIR**
 - **Commander, Naval Surface Warfare Center (NSWC)**
 - **Technical Director, NSWC**
 - **Director, NAVAIR Research and Engineering Competency**
 - **Director, NAVAIR Weapons and Targets Department**
 - **NOSSA, Navy Technical Warrant for Safety**
 - **Technical Director, Strategic Systems Project Office**
 - **Chair, Energetics IPT (Executive Secretary)**

Navy Energetics Integrated Product Team

Action Arm of the NELB

- **Chartered by the NELB:**
 - **Members of the EIPT will work together collaboratively:**
 - To support the Warfighter by developing and preserving the nation's core competencies in Energetics
 - To serve as an advisory board to the NELB on matters concerning Energetics that are of strategic importance to the Navy and the nation
 - To implement NELB guidance and approved strategic direction, and provide support in other areas of NELB responsibility
 - To lead efforts to assess, plan and implement the Navy Energetics program
 - **Representatives from NAVAIR:**
 - Deputy, NAVAIR Weapons and Energetics Department is a permanent member of the EIPT, responsible for appointing three additional NAVAIR representatives
 - **Representatives from NAVSEA:**
 - NSWC Product Area Director and one representative each from the Crane, Dahlgren and Indian Head Divisions
 - **Representative from NOSSA:**
 - Director of Weapons Assessment
 - **EIPT chair rotates each calendar year between NAVAIR and NAVSEA**

Networks for collaboration

- **Technology Oriented:**
 - Energetic Materials
 - Insensitive Munitions
 - Test & Evaluation
 - Modeling & Simulations
- **System/Product Oriented:**
 - Propulsion
 - Ordnance Support
 - Warheads
 - Fuzing
 - Littoral & Ashore Ordnance
 - Energy Generation
 - Pyrotechnics

Transition of Energetics Technology to the Warfighter...

- **Developmental products:**

- Developed over 80% of the explosives transitioned to Service use since 1985
- Developed 100% of Navy aircraft expendable infrared countermeasures
- Warheads - SLAM-ER, AMRAAM, Tomahawk, ESSM, Directional fuzes & warhead
- Rocket Motors - AMRAAM, Tomahawk, VLA, Sidewinder, HARM, Mk 22 Line Throwing Rocket
- Anti-Personnel Ordnance Breaching System (APOBS)
- Extended range naval gun propulsion

- **Concept initiation:**

- Joint Stand-off Weapon (JSOW)
- Army/Marine Corps Mongoose mine clearing system
- Joint Direct Attack Munition (JDAM)
- CCAT modular warhead
- Hypergolic penetrators for assault mine breaching
- MEMS S&A/fuzing
- Laser Guided Bomb (LGB)
- Precision imaging weapons

- **Quick reaction capability:**

- BLU-116 hard target penetrator
- BLU-118B thermobaric cave buster bomb
- Thermobaric warheads (Carl Gustav, Hellfire, SMAW)
- FMU-139 reboosting

Naval Energetics Enterprise Alignment...

- **Energetics, Safe Weapons & Ordnance, are a NAVY Need.**
- **The Naval Energetics Enterprise (NEE):**
 - Brings China Lake, Crane, Dahlgren and Indian Head Energetics expertise and capabilities together with NOSSA safety expertise under a single construct
 - Ensures teaming and collaboration across the Navy
 - Responsibility to sustain required core competency in Energetics
 - Increase efficiency/effectiveness
 - Utilize best capability
 - Minimize overlap
 - Focus investments

IM Collaboration Successes

Combat Safe Insensitive Munitions (CSIM)

ONR's CSIM proof-of-concept program assesses the effect of explosive particle properties (size and quality of the) on sensitivity, reactivity, and ignitability.

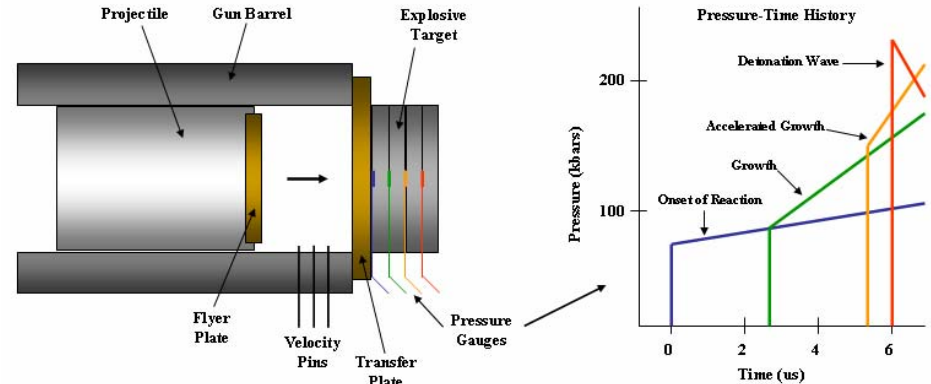

- Initially, the team is studying *Monomodal Nitramine Explosive Compositions* using 3 different morphologies, synthetic processes, and recrystallizations.
- Collaborations on shock reactivity testing have identified differences in composition ignition and reaction modes based on crystal quality and particle size. To date, findings (4 of 10 compositions) have shown:
 - Large particles (150-300 μm) shows significant reaction at the shock front
 - Small particles (Class 5, 13 μm) shows very little reaction at the shock front and greater reaction behind front
- Reaction modes are dominated by particle size; higher input pressures are required to detonate compositions containing higher crystalline quality

IM Collaboration Successes

Shipping Container

- Pumice Weapon Container Design / Demo
 - Pumice Integrated into Weapon Containers to Mitigate Sympathetic Detonation
- Iterative Container Designs - Joint Effort of NAWCWD & NSWC/IHD
 - Hydrocode modeling
 - Test asset fabrication
 - IM testing
 - Container drawings
 - Container Qualification
- Pumice container technology transitioned:
 - SLAM ER
 - JSOW

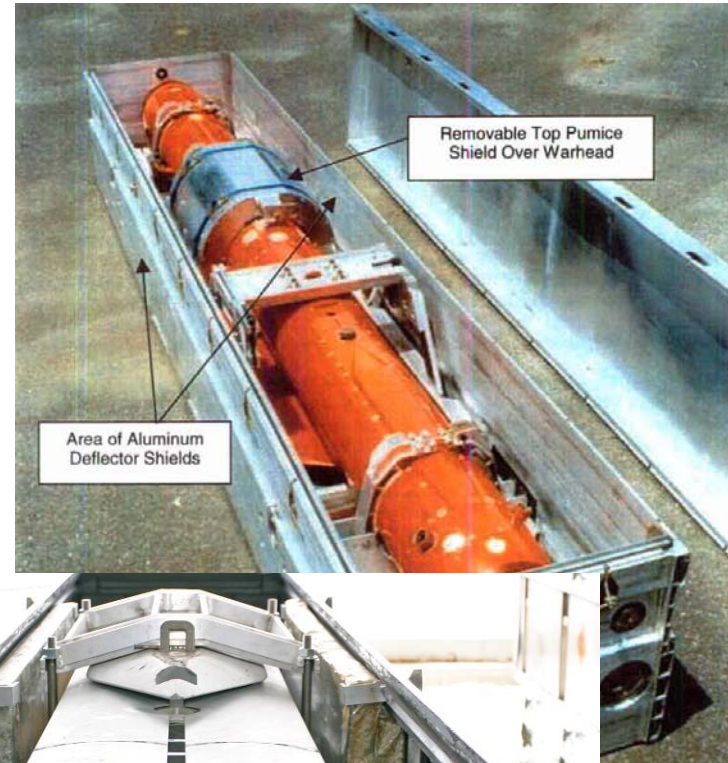

IM Collaboration Successes

Warhead Washout & Inert Load



- Periodically HARM Program Office converts older AUR missiles to training rounds
 - Warhead section removed
 - Energetic fill down loaded
 - Loaded with an inert stimulant



- Training rounds are useful in reducing target damage during testing

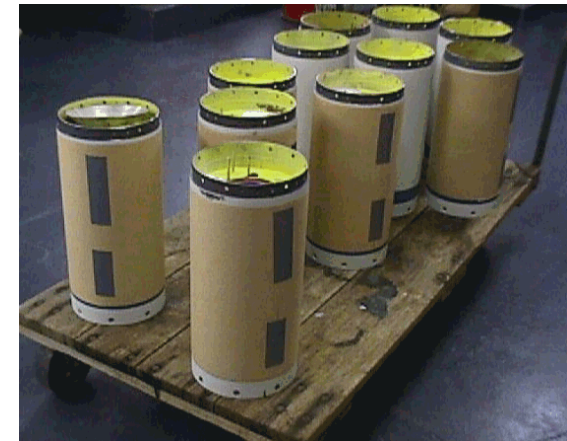

- Work Shared by NSWC/NAWC Facilities
- Delivered Warhead Units on Time and Within Budget

IM Collaboration Successes

New Low-Vulnerability Energetic Materials

RS- RDX Evaluation in PBXN-109 for GP Bomb Fill

- **Objective:** Evaluate IM Benefits of RS-RDX in GP Bomb
- **Approach:**
 - Shock sensitivity (Eurenco, Dyno)
 - Fuze Initiation (Mk-82 half-bomb) test for Eurenco PBXN-109
 - Computer Modeling and Sub-scale SD Demonstration for Eurenco PBXN-109

Holston RDX (CI 1)

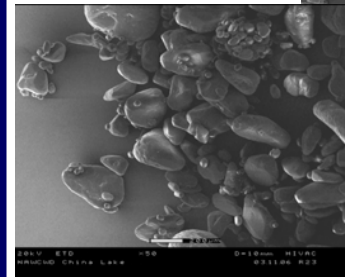
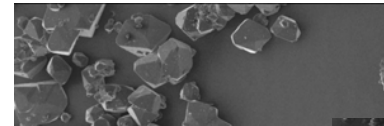

Dyno insensitive RDX (CI 1)

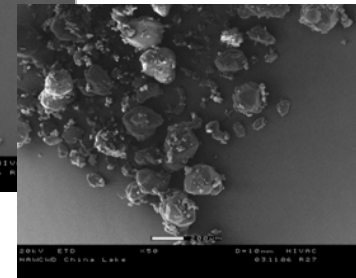

Eurenco iRDX (CI 1)

PBXN-109 Shock Sensitivity & Detonation Velocity

<u>Properties</u>	<u>Historical Data</u>	<u>OSI</u>	<u>Eurenco</u>	<u>Dvno</u>
NOL LSGT (cards) (Kbars)	186 – 195 ~24 - 22	142 ~43	113.2 ~52	113.9 ~52
Det Velocity (mm/ms)	7.480	N/A	7.497	N/A

• Results/ Conclusions:

- NOL LSGT Shock sensitivity shows RS-RDX less sensitive than normal RDX
- Detonation Velocity of RS RDX is comparable to that of normal RDX.
- Fuze initiation showed reliable initiation at - 65 F for Eurenco N-109 in half-bomb test.
- Modeling & Sub-scale SD Demo showed prompt initiation for Eurenco PBXN-109 in half-bomb tests

IM Collaboration Successes

New Vertical Launch Technologies

Objective: develop & demonstrate shielding for the MK 14 VLS canister that would mitigate SD events during its entire logistic life cycle from storage, transportation thru deployment (goal) or at least its logistic life cycle prior to deployment (threshold).

Approach: This work is a collaboration between NSWCDD & NAWCWD funded jointly by IMAD & IMTTP.

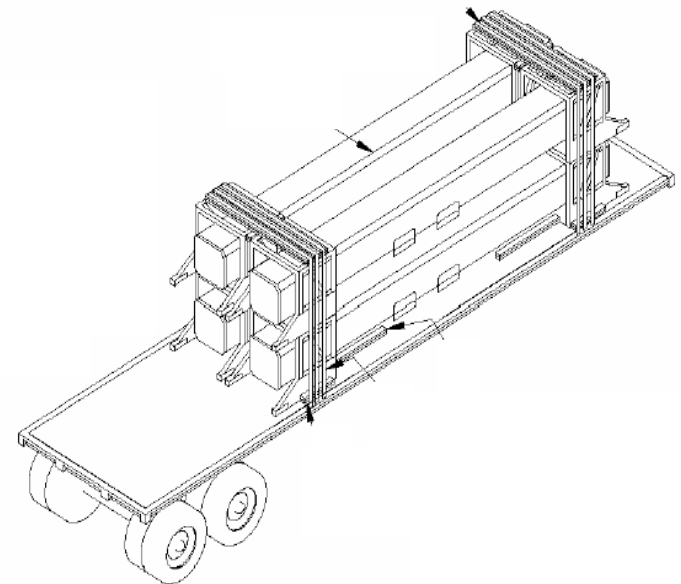
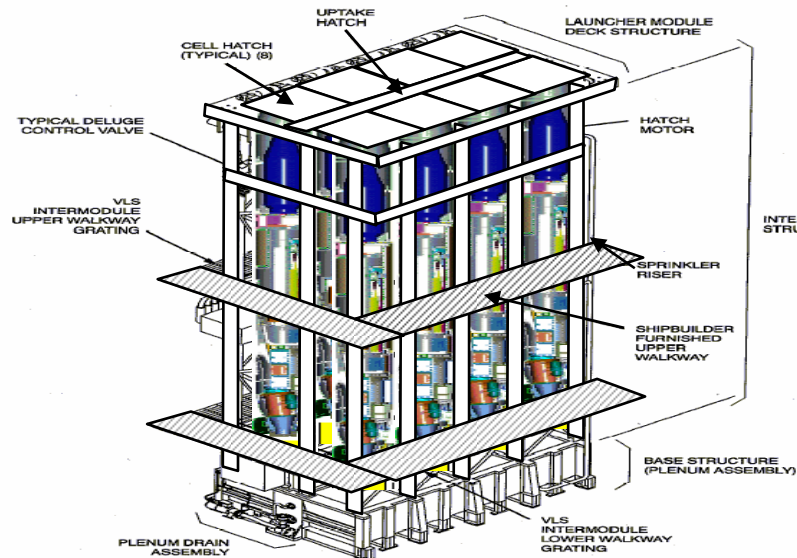

Future needs and technologies...

The Navy Energetics Enterprise (NEE) coalition will guide appropriate application of technology to weapons systems requirements of the Warfighter:

- **21st century needs include:**
 - Quick reaction capability
 - Fire support
 - Mission flexible ordnance & propulsion
 - Reduced size w/increased lethality
 - Chem-Bio defeat
 - Ship defense (torpedo, missile)
 - Military Operations in Urban Terrain
 - Special operations
 - Stand-off minefield breaching
 - Hard & Deeply Buried Target defeat
- **Numerous new Energetics technologies are emerging to meet capability based requirements:**
 - Reactive materials
 - Directed energy
 - Thermobarics
 - Micro Electro-Mechanical Systems
 - Adaptable ordnance
 - MCM hypergolic penetrators
 - Non-toxic liquid propulsion
 - Hypersonics

Summary...

- **Navy Energetics is a core military competency:**
 - Long, distinguished history in development and weaponization of Energetics for all services
- **Navy laboratory community is striving to improve service to the Warfighter:**
 - National focus for stewardship of core Navy and DoD competencies in Energetics
 - Preserve Navy capabilities through collaboration among labs
 - Long-term cost avoidance resulting from shared people and facilities
- **What's the benefit?**
 - Best technical experts brought to bear on requirements
 - Leverages strengths of Navy laboratories and industry
 - Makes Sea Power 21 a reality

The Future

- **A core military and Navy competency is at risk:**
 - DoD focus is on C4ISR, sensors, electronics and software
 - Recapitalization to meet new global threat (CNO Guidance)
 - Downsizing and budget constraints
- **The NEE via the NELB and the EIPT will:**
 - Enhance alignment with the Warfighters' vision
 - Provide focus for stewardship of core Navy/national competencies in Energetics
 - Foster rapid transition of technology to the warfighter
 - Increased value to meet Warfighters' needs...best technical solutions
 - Increased efficiency...long-term cost avoidance through sharing of people and facilities

