

# NEW BUILDING COMMISSIONING (Cx)

Gary Bauer PE

HQUSACE

202 761-0505

presented by

Dale Herron

ERDC/CERL

(217) 373-7278

# NEW BUILDING Cx

- QUESTION:
  - Does the Corps of Engineers perform New Building Cx for our customers on MILCON projects?
- Answer??
  - A. Yes
  - B. No
  - C. Maybe

## **What is New Building Commissioning (Cx)?**

Cx is a quality assurance process for buildings from pre-design through design, construction, and operations. It involves achieving, verifying, and documenting the performance of each system to meet the building's operational needs within the capabilities of the documented design and equipment capacities, according to the owner's functional criteria.

Commissioning includes preparing and enhancing building documentation and training operation and maintenance personnel. The result should be fully functional systems that can be properly operated and maintained throughout the life of the building.

(ASHRAE, 2004)

# Building Cx Association (BCA)

**We define the basic purpose of commissioning as follows: *"The basic purpose of building commissioning is to provide documented confirmation that building systems function in compliance with criteria set forth in the Project Documents to satisfy the owner's operational needs."* This definition is based on the critical understanding that the owner must have some means of verifying that their functional needs are rigorously addressed during design, construction and acceptance.**

# NEW BUILDING Cx PROCESS

- QA process including the following phases
  - Pre-design
  - Design
  - Construction
  - Operations.
- Verify & Document performance
  - Building systems
  - Train O&M staff
  - Provide fully functioning systems

# CORPS PROCESS

- **Project initiation & plan development**
  - Planning Charrette
    - Produce Draft 1391
  - Workload analysis
  - Initiate project in P2
  - Verify 1391
  - Develop Project Management Plan (PMP)
    - Establish Project Delivery Team (PDT)
      - Dev. Milestones & activities
    - Develop Acquisition Plan
    - Develop Resource Estimates
      - Request P&D funds

# CORPS PROCESS

- **Design Process**

- Advertise, Evaluate Proposals and Select A-E
- In house pre-design activities
  - Verify project scope
  - Initial tasking & funding document
  - Pre-design conference
  - Baseline budget & schedule
  - Request & Receive funds

# CORPS PROCESS

- **Project definition**
  - Notice to proceed
  - Design charrette
    - ECB 2002-13
    - AR 415-15
    - DA PAM 190-51
    - TI's 800-01 & 802-01
    - ER 1110-3-1300
  - Develop concept design
  - Submit estimate



# CORPS PROCESS

- **Project definition (Continued)**
  - Engineering Tech review
  - Construction BCOE
  - User Functional review
  - VE
  - Coordinate comments
  - Revise concept design
  - Pay A-E
  - Authorize final design

# CORPS PROCESS

- **Final design & D-B RFP Development**
  - Receive directive & funds
  - Issue NTP
  - Develop final design
  - Develop source selection plan
  - Submit pre-final design
  - Prepare final RFP

# CORPS PROCESS

- **Final design & D-B activities (Continued)**
  - Tech review
  - BCOE review
  - Functional review
  - Coordinate comments
    - Revise final design
  - Develop Special Clauses
    - Submit Final 3086
  - Back check
  - Ready To Advertise (RTA)

# CORPS PROCESS

- **Advertising and award**
  - Authority to advertise
  - Fed Biz Ops announcement
  - Advance notice to bidders
  - Receive bids
    - Evaluate Bids
    - Conduct pre-award survey
  - Receive proposals
    - Conduct source selection
  - Develop award CWE
  - Request funds and authority to award
  - Award

# CORPS PROCESS

- **Construction**
  - Precon
  - NTP
  - QA/QC & safety plans
  - Schedule review and accept
  - Submittals
  - Construction placement
  - Progress payments

# CORPS PROCESS

- **Construction (Continued)**
  - Process mods
  - Red zone (Performance Documented)
    - Testing complete or on schedule
    - Tab done
    - HVAC commissioning complete/on schedule
    - Test reports complete
  - Prefinal inspection
  - Punch list
  - Final inspection

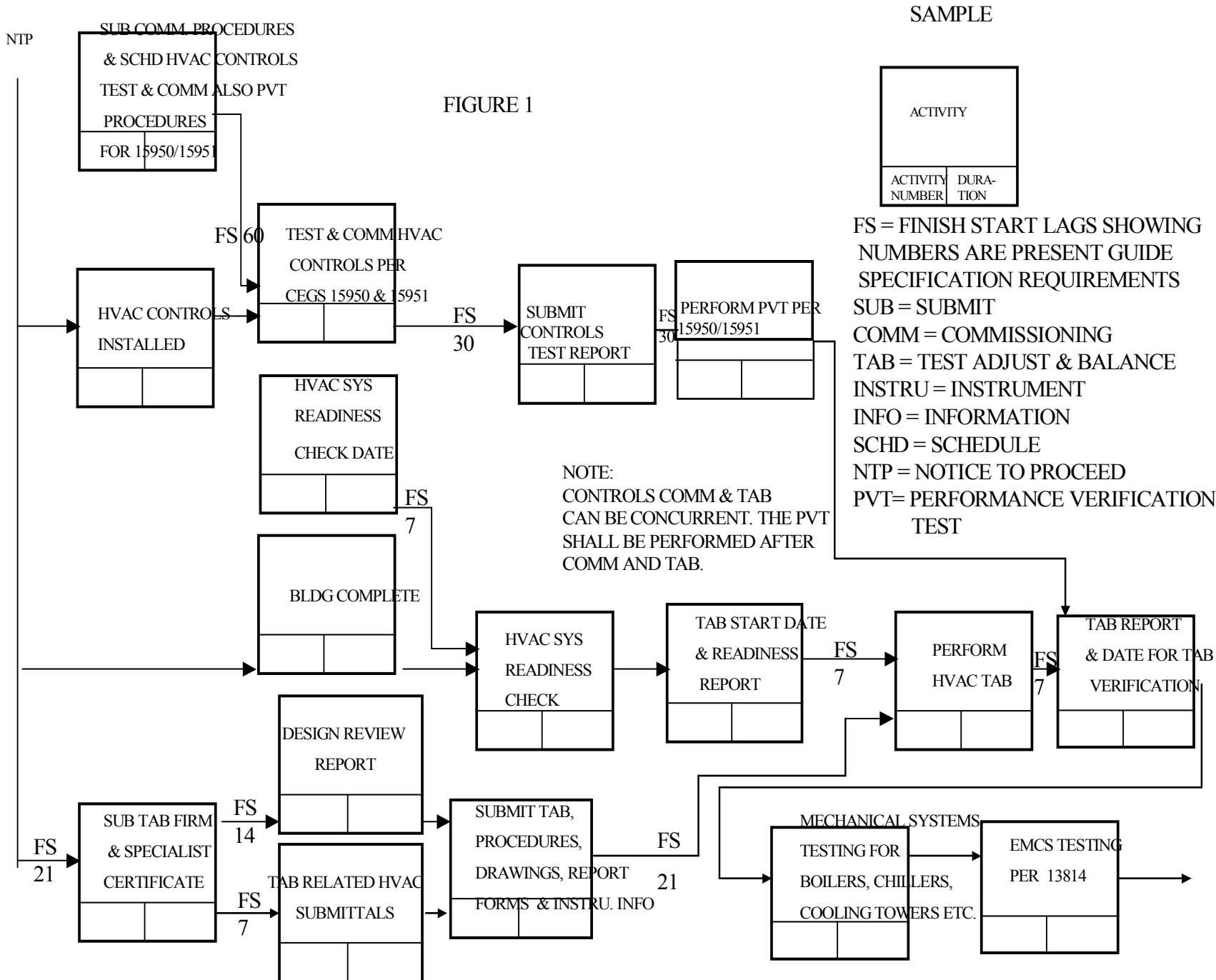

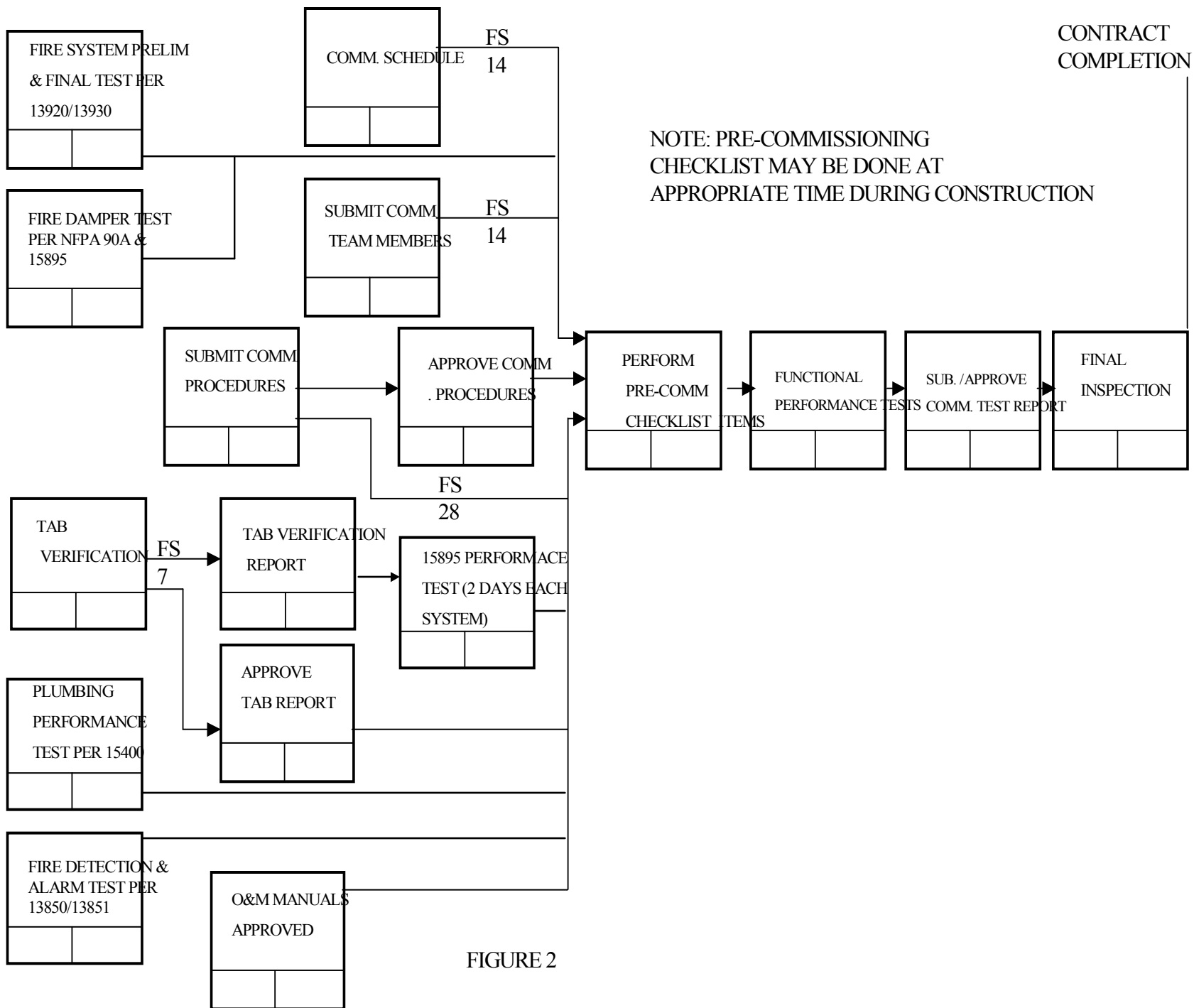

FIGURE 2



# CORPS PROCESS

- O&M & warranty
  - User O&M
    - Training complete attendance documented
    - Manuals turned over
    - As-builts complete and turned over
  - 4 month warranty inspection
  - 9 month warranty inspection

# CORPS PROCESS

- Closeout
  - Beneficial occupancy
  - Physically complete
  - Transfer document
  - Final A-E evaluation
  - Close out design contract
  - Construction contractor evaluation

# CORPS PROCESS

- Closeout (Continued)
  - Physical close out of contract
  - Final 1354
  - Close sub accounts
  - Fiscal close out of project

# MILITARY DESIGN / CONSTRUCTION PROCESS

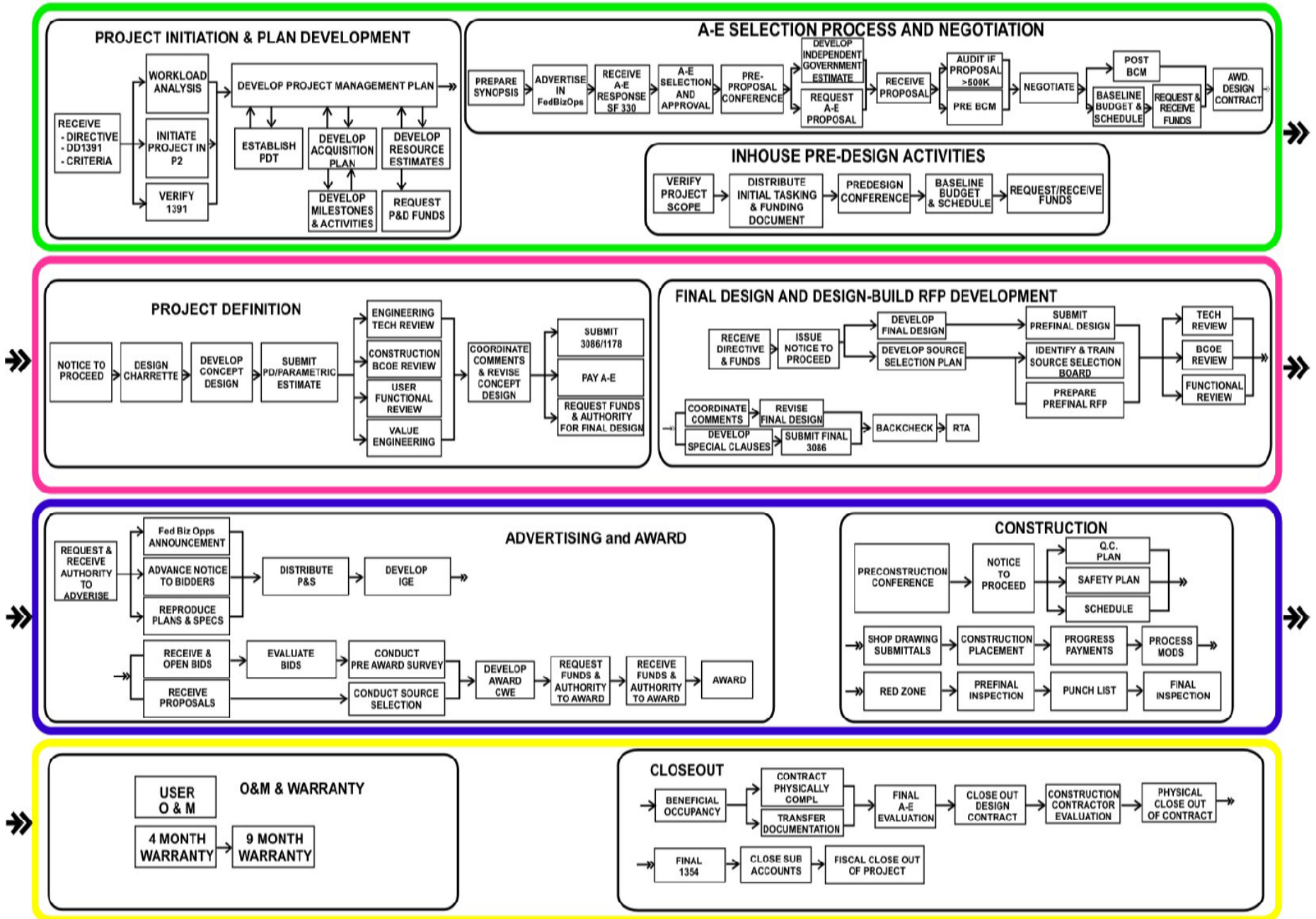

# NEW BUILDING Cx

- QUESTION:
  - Does the Corps of Engineers perform New Building Cx for our customers on MILCON projects?
- Answer??
  - A. Yes
  - B. No
  - C. Maybe

# NEW BUILDING Cx

- QUESTION:
  - Does the Corps of Engineers perform New Building Cx for our customers on MILCON projects?
- Answer:
  - A. Yes

Questions??

EXECUTION